

# Superintendent's Report Orange Public Schools “Good to Great”



Gerald Fitzhugh, II, Ed.D.  
Superintendent of Schools  
“The Teaching Superintendent”  
December 14, 2021



# NJIT 3D Printed Bridge Competition

STEM Innovation Academy of the Oranges

---

Brianna Ajawuihe, Sao Barbu, Rose Dieujuste, Ovianny Philizaire

Introduced by Tina Powell, Ed.D.

Assistant Superintendent of Innovation and Systems

December 14, 2021





# Sao Barbu, Grade 12

## *Mechanical Engineering Track*

- **My colleges courses:**
  - NJIT's Pre-Calculus
  - NJIT's HUM 101 English Composition
  - NJIT CHEM 125/125A Chemistry I
- **My AP courses:**
  - Environmental Science
  - AP English Lit and Comp
- **Intended College Major:**
  - Computer Engineering
- **Extracurricular activities:**
  - NJIT's Makerspace PACE Training Program
  - Drone Club

# Rose Dieujuste, Grade 11

## *Mechanical Engineering Track*

- 4.09 GPA
- **My colleges courses:**
  - NJIT CHEM 125/125A Chemistry I
  - NJIT's HUM 101 English Composition
- **My AP courses:**
  - Environmental Science
- **Intended College Major:**
  - Business and Finances
- **Extracurricular activities:**
  - Cheerleading
  - Transportation YOU
  - Real World Connections (RWC)
  - Volleyball Club



# Oviany Philizaire, Grade 11

## *Mechanical Engineering Track*

- 4.41 GPA
- **My college courses:**
  - NJIT CHEM 125/125A Chemistry I
  - HUM 101 English Composition
  - NJIT Math 111 Calculus I
- **My AP courses:**
  - Environmental Science
  - Calculus I
- **Intended College Major:**
  - English Secondary Education
- **Extracurricular activities:**
  - Cheerleading
  - OHS MMT
  - Youth Orchestra
  - Berry Butterflies
  - Transportation You
  - Mature Teens Movement
  - Seeds for Fortune



# Brianna Ajawuihe, Grade 11

## *Mechanical Engineering Track*

- **My college courses:**
  - NJIT CHEM 125/125A Chemistry I
  - HUM 101 English Composition
  - NJIT Math 111 Calculus I
- **My AP courses:**
  - Environmental Science
  - Calculus I
- **Intended College Major:**
  - English Secondary Education
- **Extracurricular activities:**
  - Track
  - Cheerleading
  - Transportation You
  - Real World Connections (RWC)
  - NJIT Makerspace PACE Training Program
  - Volleyball Club



# The Competition

---

- On Saturday, November 20th, 2021 the first **3D Printed Bridge Competition** in the region was hosted at NJIT's Makerspace.
- This competition was an acknowledgment of the importance of creative thinking within engineering.





# Participating Teams

---

## **Collegiate Division**

- New Jersey Institute of Technology
- Princeton University
- Stevens Institute of Technology

## **High School Division**

- STEM Innovation Academy of the Oranges
- Applied Technology High School
- Middlesex County Academy for Science, Mathematics and Engineering Technologies

# Research

Our team conducted an extensive research to identify the best bridge type to carry the most load within constraints.

The **foundation**, **substructure**, and **superstructure** are the three primary bridge sections where all of the essential components are located.

## Types of Bridges

- Beam bridges
- Truss bridges
- Arch bridges
- Suspension bridges
- Cantilever bridges.
- Cable-stayed bridges

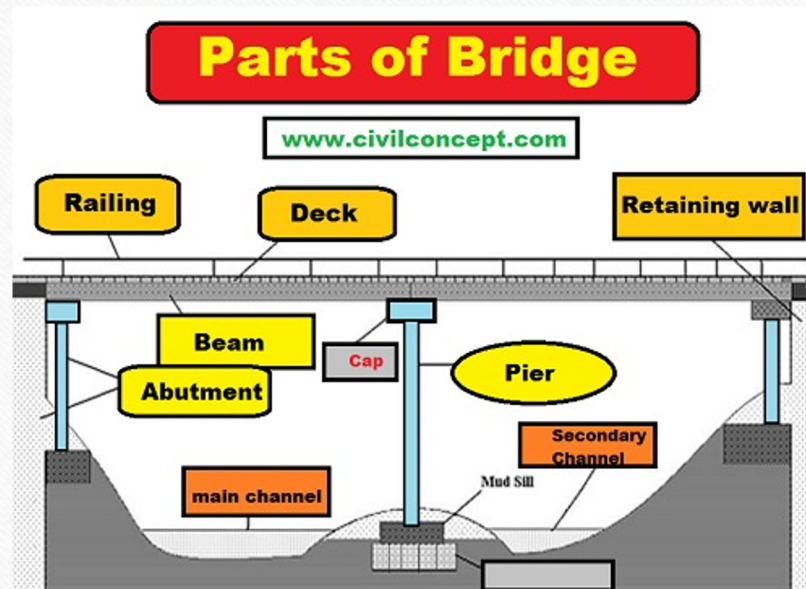

A **Truss Bridge** is made up of interconnected triangles that spread the weight over a larger area. This permits the bridge to support a higher weight capacity while using less material in its construction.





## Draft Design



Top View

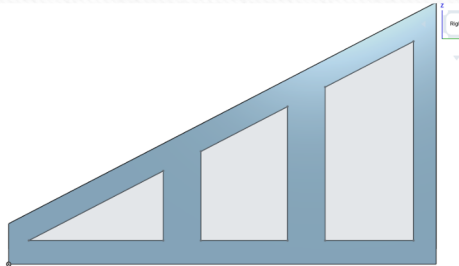

Side view

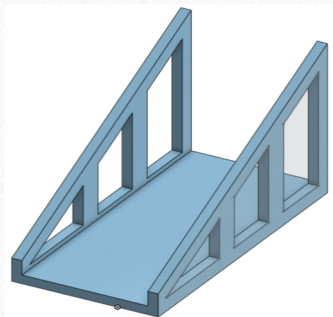

Isometric view

## Our Design (End Pieces)

### Constraints

- Minimum two bridge sections at least 200 mm length per section.



- For the side of the end piece, we chose a triangle-shaped design in order for it to be able to hold more weight. The drill holes are included so that the three parts of the bridge and the top can be connected to each other

## Final Design



Top View

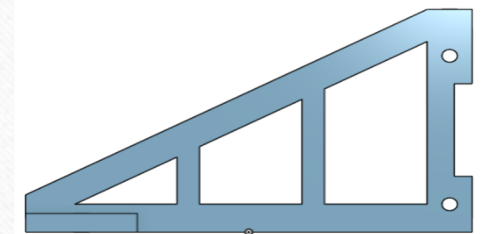

Side view

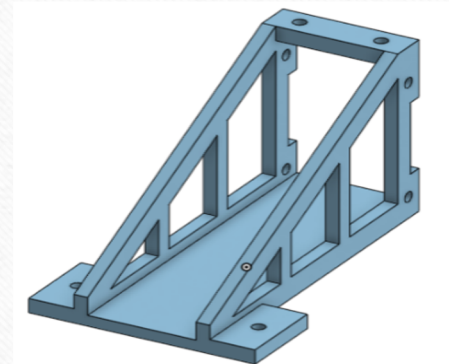

Isometric view

## Draft Design

### Top View

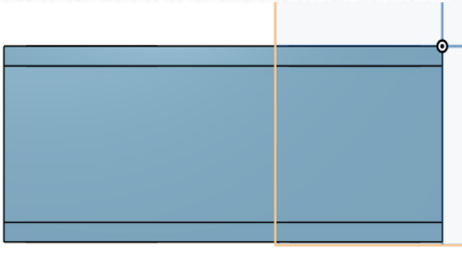

### Front View

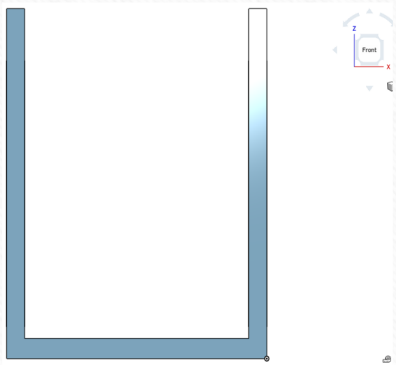

### Isometric view

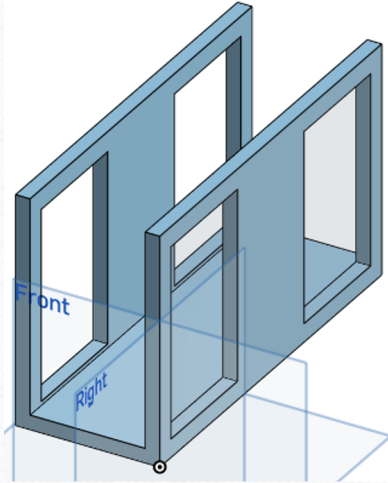

### Side View

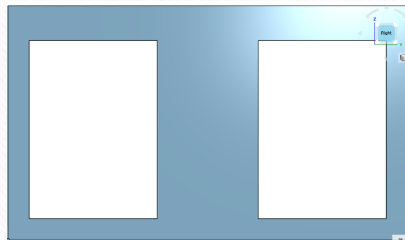

## Design (Middle Piece)

### Top View

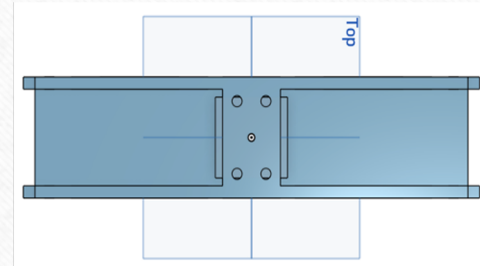

### Front View

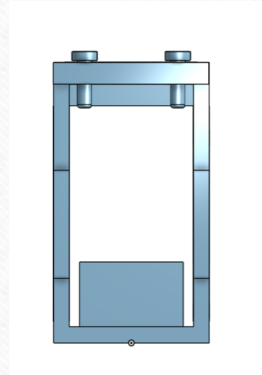

### Isometric view

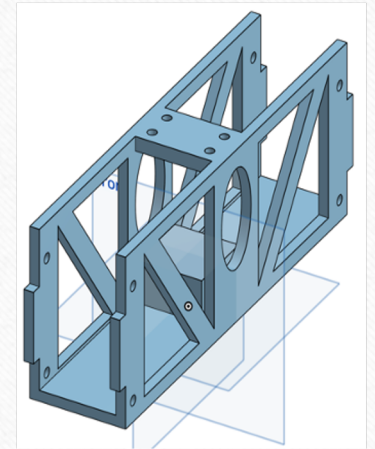

### Side View

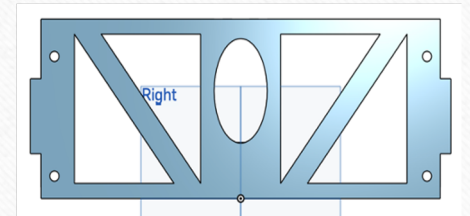

## Final Design



## Design (Top Piece)

The top piece that we incorporated into our design helps to create an extra layer of stability onto our bridge. This ensures that we are provided with the maximum amount of strength and support that is necessary.

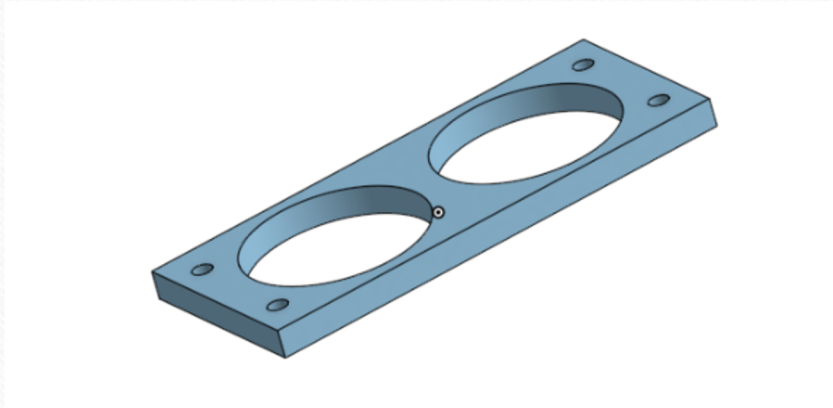

Isometric View

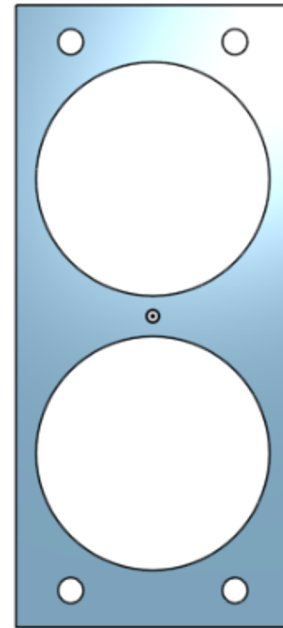

Top View

# Overall Design

Top View

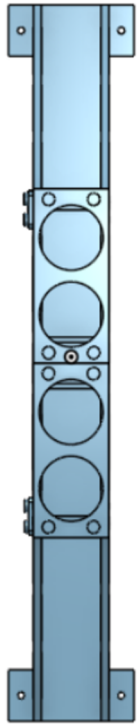

When assembled, all the pieces of the bridge complement to each other and are made to help support the weight that the bridge will have to hold. That is where the symmetry comes in. Because the bridge is symmetrical with respect to its midpoint, the entire length of the bridge should be able to bear the weight of the load.

Side View

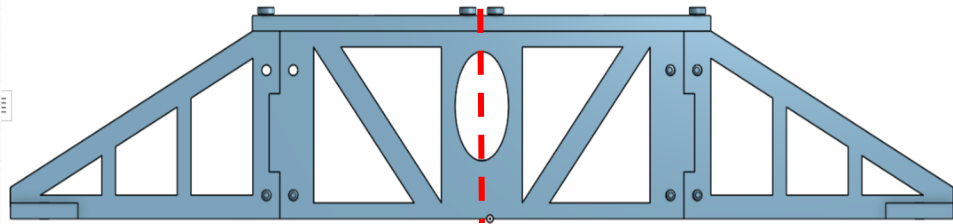

Isometric View

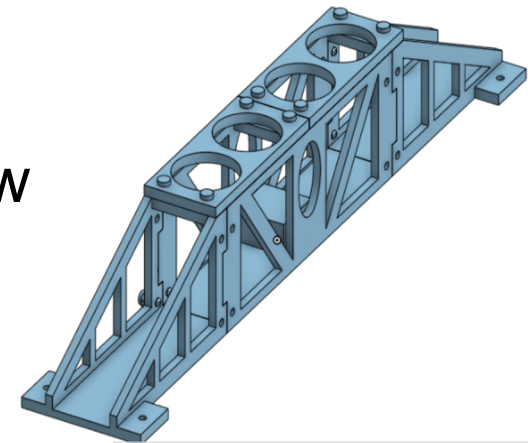



# Drawing File

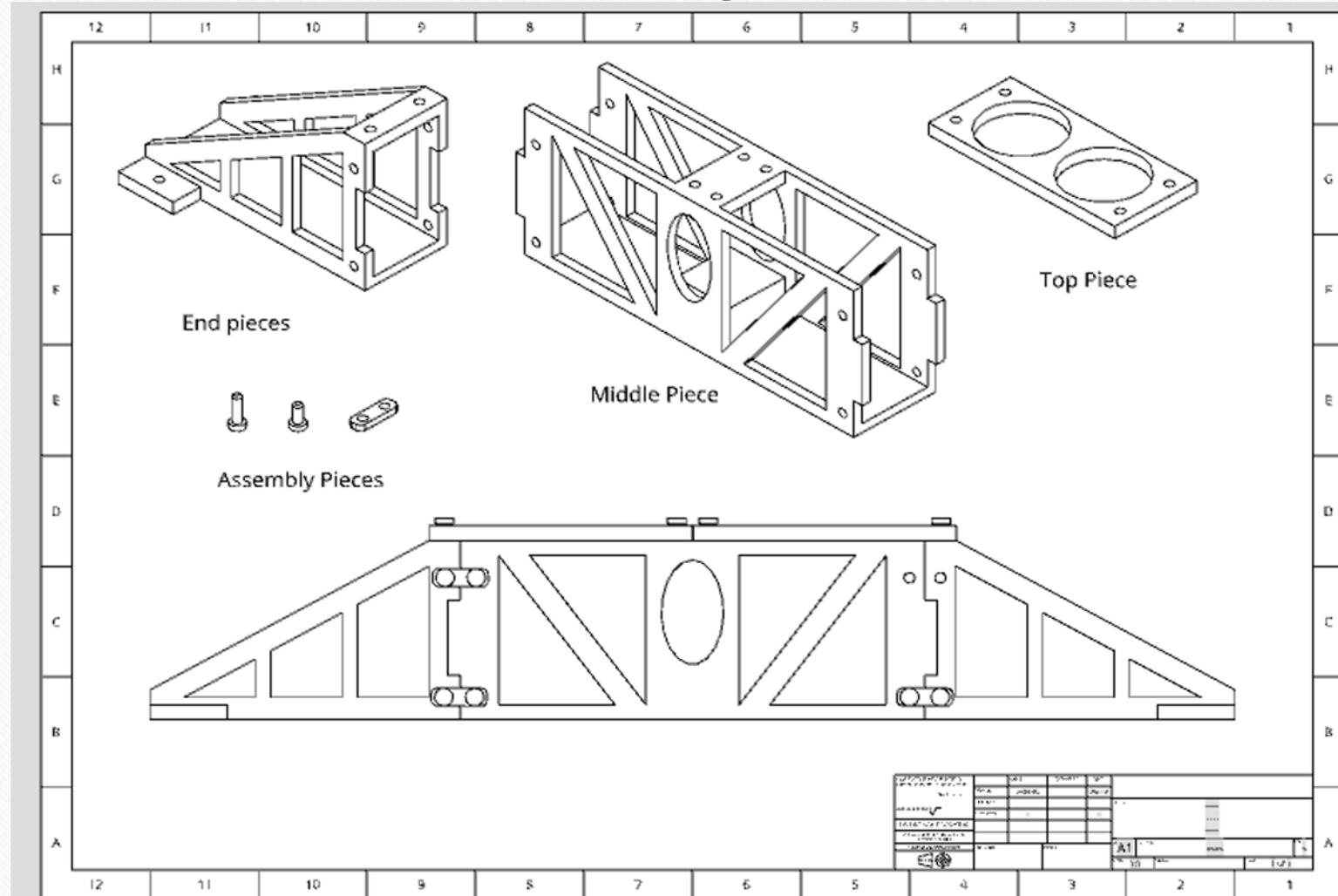

# Bridge Assembly Process



- Bridge assembly was part of the competition.
- Two students were allowed to assemble the bridge
- **Assembly Time:** 6 minutes 40 seconds



# Bridge Testing

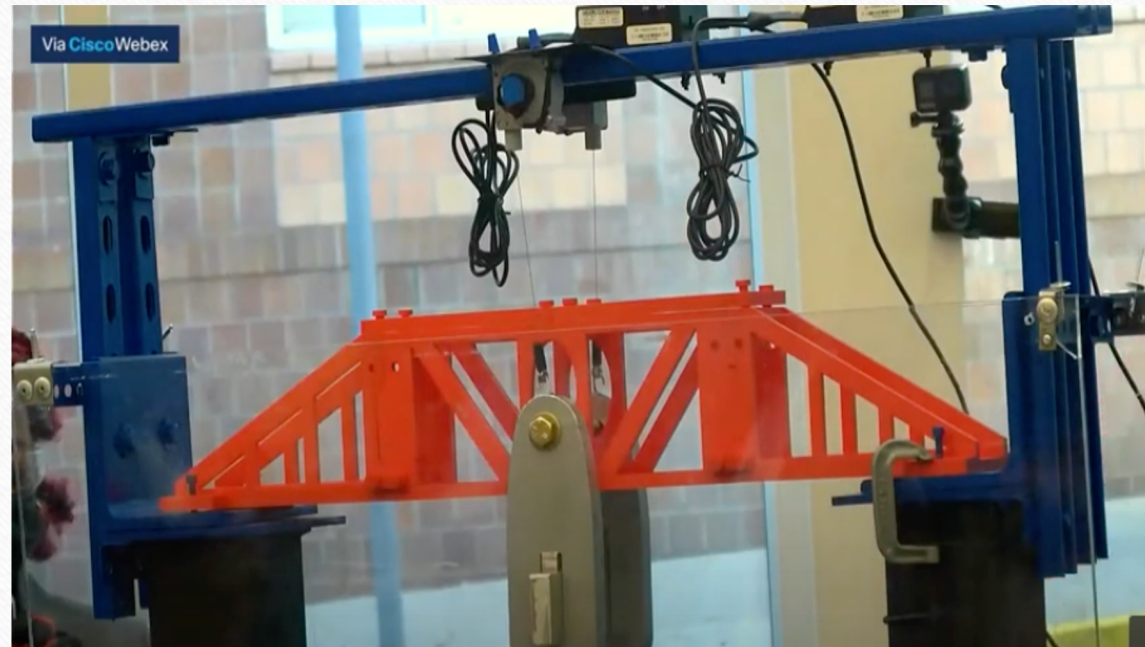

Our bridge withstood about 60 pounds of load!!



# Awards

STEM Innovation Academy of the Oranges was awarded **FIRST PLACE** overall for the high school division.





## Special Thanks

Dr. Devonii Reid, STEM Innovation Academy of the Oranges

Ms. Allison Brazier-Martin, Engineering Teacher

Mr. David Aytas, Project Mentor (STEM Focused-Learning Supervisor)



# Celebration of Students

## Student of the Month Announcement

---



Gerald Fitzhugh, II, Ed.D.  
Superintendent of Schools  
“The Teaching Superintendent”  
December 14, 2021



# Students of the Month

## November 2021

### Congratulations to our STAR Students!

Name of School	Student of the Month	Name of School	Student of the Month
Orange High School	Juan Diaz Grade Twelve	Lincoln Avenue School	Bryan Palta Morocho Grade Six
Orange Preparatory Academy	Isaias Ramos Grade Eight	Oakwood Avenue School	Camoorra Lee Jones Grade One
Twilight U	Chris Isaac Grade Twelve	Rosa Parks Community School	James Evra Grade Six
Cleveland Street School	Ma-khi Griffith Grade Two	Park Avenue School	Christnyse Destine Grade Seven
Forest Street School	Scarleth Santos Grade Five	STEM Innovation Academy of the Oranges	Mark Rodriguez Grade Ten
Heywood Avenue School	Dzemla Toge Grade Two	Central Elementary School	Kaitlyne Calixte Grade One



Governor's Educator of the Year  
Celebration!!! Congratulations to all  
of the NOMINEES



Glasshebra Jones  
Executive Director  
Office of Human Resources  
December 14, 2021



# Governor's Educator of the Year Nominees

---

- Rosa Parks Community School: Jean St. Fort (Elementary Educator)
- Esther Lawal (School Guidance Counselor)
- Orange High School: Anthony Dietrick (Special Education Educator)
- Darrell Pope (Paraprofessional)
- Orange Preparatory Academy: Joel Lemke (Social Studies Educator)
- Myledy Romero (School Guidance Counselor)
- Orange Early Childhood Center: Wilvana Mesidor-Vincent (Pre-School Educator)

# Governor's Educator of the Year Nominees

---

- Oakwood Avenue School: Jesenia Lopez (Elementary Educator)
- Deborah Celestine (Paraprofessional)
- Park Avenue School: Shannon Keogh (Mathematics Educator)
- Cheryl Forbes: (CST School Social Worker)
- Scholars Academy: Regina Nadbielny (STEM Educator)
- Claire Philistin: (CST School Social Worker)
- Central Elementary School: Elizabeth Mathis-Smith (Elementary Educator)
- Marsha Younge (Paraprofessional)



# Governor's Educator of the Year Nominees

---

- Cleveland Street School: Edward Harris (Health and Physical Education Educator)
- Simone Davis: (Paraprofessional)
- STEM Innovation Academy of the Oranges: Gabriella Macri (Science Educator)
- Dana Gregory: (Mathematics Educator)
- Heywood Avenue School: Sandra Guerra (Elementary Educator)
- Jasmin Sair: (Paraprofessional)
- John Robert Lewis Early Childhood Center: Sakeenah Raheem (Pre-Kindergarten Educator)
- Sandra Taborda: (Paraprofessional)
- Lincoln Avenue School: Audrene Rowe (ESL Educator)
- Sean Snead: (Educational Media Specialist)



# Congratulations!!

---

- The Orange Public School District is so very proud of each of our Governor's Educator of the Year Nominees. It is evident by your peers, that you exhibit the tenacity and drive to educator our scholars.
- We appreciate your efforts daily as you lay the foundation for us to move the district from "Good to Great"



# District Goals

## Reminder of Our Goals

---



Gerald Fitzhugh, II, Ed.D.  
Superintendent of Schools  
“The Teaching Superintendent”  
December 14, 2021



# COMMUNITY

## DISTRICT

### SCHOOL

#### STUDENTS

STATE  
POLICIES

SOCIAL SERVICES

BUSINESS &  
INDUSTRY

FEDERAL  
POLICIES

FAMILIES

RESOURCES

SYSTEMS

FAMILIES

LOCAL  
COMMUNITY

RELATIONSHIPS

PRINCIPALS  
TEACHERS  
STAFF

HIGHER  
EDUCATION

TRANSPORTATION

CULTURE &  
CLIMATE

DISTRICT  
POLICIES

#### STUDENTS

AFTER  
SCHOOL  
PROGRAMS

SCHOOL BOARD

DISTRICT  
DEPARTMENTS

COMMUNITY  
ENGAGEMENT

ELECTED  
OFFICIALS

CURRICULUM

MUNICIPAL  
SERVICES

LOCAL POLITICS

COMMUNITY  
BASED  
ORGANIZATIONS



# District Goal #1: 21<sup>st</sup> Century Integration

**Overarching Overview of the Goal:** The Orange Public Schools will continue to invest in its teachers. The district values and promotes a culture of excellence in teaching and learning through increased and improved opportunities for quality, sustained professional development that address district needs and individual school needs as outlined by data points. The emphasis has been on best practices in teaching and learning. As a result of the pandemic, a continued understanding of providing targeted and intentional delivery of instruction is paramount district-wide.

**Subgoal One: Increase in the number of job-embedded professional learning opportunities that incorporate the expertise of building principals planning alongside district administration by 60% from SY 20-21**

- Administrative Meetings will continue to be instructionally-focused learning sessions for principals and district administrators. Ultimately, all training sessions will be germane to data points resulting from walk-through trend analyses.
- Administrative meetings will continue to have instructionally focused agendas with accompanying sign in sheets. Zoom/Google Meet as well as in person meetings will take place for horizontal and vertical articulation supports to build content knowledge and pedagogy if applicable.

# District Goal #1: 21<sup>st</sup> Century Integration

**Overarching Overview of the Goal:** The Orange Public Schools will continue to invest in its teachers. The district values and promotes a culture of excellence in teaching and learning through increased and improved opportunities for quality, sustained professional development that address district needs and individual school needs as outlined by data points. The emphasis has been on best practices in teaching and learning. As a result of the pandemic, a continued understanding of providing targeted and intentional delivery of instruction is paramount district-wide.

**Subgoals 2 & 3: By May 2022, 60% of students in each preparedness group will meet or exceed their assigned end of year growth target in mathematics.**

- The assessments that will be used to measure progress towards the assigned growth targets include the iReady Diagnostic, NWEA MAP, District Benchmark Assessments, and select Performance Tasks in the area of Mathematics.
- The district will continue to report out all data in the area of mathematics.

**By May 2022, 60% of students in each preparedness group will meet or exceed their assigned end of year growth target in ELA.**

- The assessments that will be used to measure progress towards the assigned growth targets include the FRA, SRI, Insight, District Benchmarks, and Performance Tasks in the area of English Language Arts.
- The district will continue to report out all data in the area of English Language Arts.



**District  
Goal #1:  
21<sup>st</sup>  
Century  
Integration**

**Overarching Overview of the Goal:** The Orange Public Schools will continue to invest in its teachers. The district values and promotes a culture of excellence in teaching and learning through increased and improved opportunities for quality, sustained professional development that address district needs and individual school needs as outlined by data points. The emphasis has been on best practices in teaching and learning. As a result of the pandemic, a continued understanding of providing targeted and intentional delivery of instruction is paramount district-wide.

**Subgoal 4: Provide Learning Loss Support through disaggregation of data and pre-assessments across content areas.**

- Institute intervention supports at the elementary level through the master schedule to remediate areas of academic concern.
- Provide High School Students with SAT and NJSLA Prep courses in the master schedule.
- Partner with Bank Street College to provide Early Childhood Supports for the district's youngest learners.

# District Goal #2: Community Engagement

**Overarching Overview of the Goal:** The Orange Public Schools will continue a system of consistent communication system for disseminating and receiving information between school administration, teachers, staff, students, parents, and the community.

**Subgoal 1: Increase the timeliness, access, and effectiveness of all communication with all stakeholders via multiple measures by 50% from the previous school year (the previous year was at a 35% increase.)**

- Social Media Platforms & Website (Instagram, Facebook, and Twitter)-Utilize the platforms for immediate news-worthy information as well as the district website via the latest news and announcements section.
- RoboCalls via School Wires at the district and school levels; we are incorporating more text to speech and emails for SY 21-22 at 35%.
- Superintendent's Report (online access to staff and community stakeholders) the day immediately following the board meeting by noon.
- Routine face-to-face opportunities to engage with community and stakeholders via PTO, Back to School Nights, Report Card Conference Nights, Community Events within Orange Township as well as partnership meetings based on those established and forthcoming within the school district. We will continue the parent and student councils at the Superintendent's Level.
- Provide Bilingual Supports for all families to ensure their engagement within the school district.



# District Goal #2: Community Engagement

**Overarching Overview of the Goal:** The Orange Public Schools will continue a system of consistent communication system for disseminating and receiving information between school administration, teachers, staff, students, parents, and the community.

**Subgoal 2: Increase the use of emerging and available communications outlets to transmit information by 30%**

- Partner with universities (local and throughout the state) in order to get information to prospective candidates for job fairs and other industry level announcements. We will conduct virtual and in-person job fairs as well to widen the search for potential candidates outside of the University realm.
- Continue to utilize the Orange Public School App for more timeless information.
- Continue to utilize the Emergency Pop Up on the website for transmitting important, time sensitive information weekly.
- Provide Translations on all documents that are disseminated from schools and district offices.

**District  
Goal #2:  
Community  
Engagement**

**Overarching Overview of the Goal:** The Orange Public Schools will continue a system of consistent communication system for disseminating and receiving information between school administration, teachers, staff, students, parents, and the community.

**Subgoal 3: Continue Parent and Student Councils at the Superintendent's Level**

- Have monthly meetings with parents and students about academics as well as self-care supports; student council meetings will take place separately from the parent council.
- Continue the Bilingual Parent Advisory and ensure that the meetings are quarterly.
- Continue the Special Education Advisory Council Meetings and ensure that the meetings take place quarterly.
- Continue the Early Childhood Advisory Council Meetings and ensure that the meetings take place quarterly.



# District Goal #3: Facilities and Finance

**Overarching Overview of the Goal:** The Orange Public Schools will continue to redesign the fiscal management, operations, and human resources of the organization to ensure a system of accountability, transparency, and efficiency for the optimal delivery of services.

**Subgoal 1: Create a district budget under constraints that accommodates and supports the needs of central office departments, all schools and students while sustaining systems that have yielded results through a strategic assessment of data**

- Analyze and clarify how all budgeted funds are allocated and expended at the department and school levels
- Examine and evaluate contracted services provided to the district and continuously improve effectiveness
- Identify and execute capital projects (short term/long term, prioritized, and categorized on the basis of need)

# District Goal #3: Facilities and Finance

**Overarching Overview of the Goal:** The Orange Public Schools will continue to redesign the fiscal management, operations, and human resources of the organization to ensure a system of accountability, transparency, and efficiency for the optimal delivery of services.

**Subgoal 2: Implement innovations that empower teaching and learning as well as efficiently allocate funding within their locations**

- Redesign district- and school-level organization charts that provide departments and schools with a blueprint of essential instructional and non-instructional positions
- Provide a new vehicle to budget more efficiently and effectively at the district and school levels
- Create a staff retention program via the Kathy Kram Model for novice educators district wide.
- Create a long-term and short-term facilities development plan to outfit buildings district wide in the effort of expanding programming throughout the school district.



# District Goal #4: Social and Emotional Supports

**Overarching Overview of the Goal:** The Orange Public Schools will continue to ensure that all students will receive social and emotional support to become adaptable, confident citizens who embody self-awareness and strong interpersonal skills, and who are capable of responsible decision-making and managing their emotions and behaviors.

**Subgoals 1 & 2: Provide research-based curriculum to strengthen students' social/emotional relationships**

- Continue to utilize Restorative Practices as a means of providing effective supports to students in the effort of problem solving.
- Utilization of the ESSER II funding in mental health to provide students another avenue to combat social-emotional concerns and thus remediate areas of deficiency related to mental health.

**Enhance community-based partnerships in order to assist students and families**

- Utilize the District's community engagement officer to assist school-based staff with establishing partnerships to support families and students and thus have a vehicle to support families Pre-K through Twelve.
- Provide self-care supports for students and families based on surveys (conducted twice per year) as well as discussion with support staff members.

# COVID-19 Vaccination & Safety Reminder



Gerald Fitzhugh, II, Ed.D.  
Superintendent of Schools  
“The Teaching Superintendent”  
December 14, 2021



# Vaccination Cycles within our District

---

## **I. Lincoln Avenue School at 4:00pm - 7:00pm**

- **Address:** 216 Jackson Avenue, Orange, NJ
- First Dose: 12/16/21
- Second Dose: 1/6/22

## **II. Heywood Avenue School at 4:00pm - 7:00pm**

- **Address:** 421 Heywood Avenue, Orange, NJ
- First Dose: 1/13/22
- Second Dose: 2/3/22

## **III. Orange Preparatory Academy at 4:00pm-7:00pm**

- Address: 400 Central Avenue, Orange, NJ
- First Dose: January 7, 2022
- Second Dose January 28, 2022

## **IV. Oakwood Avenue School 4:00pm-7:00pm**

- Address: 135 Oakwood Avenue, Orange, NJ
- First Dose: January 10, 2022
- Second Dose January 31, 2022

# Reminder to Families

## Keeping Everyone SAFE

---

- If your child is sick or exhibiting symptoms, they are NOT to come to school. Get your child tested. What does this do? This allows for staff and students to remain safe and thus not have to quarantine. We must all be responsible during this pandemic. Reminder, the pandemic is NOT over....
- On the next slide, I am going to remind everyone of the symptomology...



# Symptoms of COVID-19

---

- Symptoms may appear 2 -14 days after exposure to the virus. People with these symptoms may have COVID-19:
  - Fever or chills
  - Cough
  - Shortness of breath or difficulty breathing
  - Fatigue
  - Muscle or body aches



# Additional Symptoms of COVID-19

---

- Headache
- New loss of taste or smell
- Sore throat
- Congestion or runny nose
- Nausea or vomiting
- Diarrhea
- **Special Note:** All schools are outfitted with isolation rooms should students become sick during the day. The most important component is that when called, the parent/guardian must come immediately to pick up the sick child. This allows for lessening the spread of illness.





# Hand Hygiene & Respiratory Etiquette

---

- We will continue to teach and reinforce hand washing with soap and water for at least 20 seconds. If soap and water are not readily available, hand sanitizer that contains at least 60% alcohol can be used (for staff and older children who can safely use hand sanitizer).
- We will inform students and staff to cover coughs and sneezes.
- Used tissues should be thrown in the trash and hand hygiene as outlined above should be performed immediately.
- We will maintain adequate supplies including soap, hand sanitizer with at least 60 percent alcohol (for staff and older children who can safely use hand sanitizer), paper towels, tissues, and no touch trash cans.
- Hand hygiene should take place: Upon arrival at school. Before and after meals and snacks. After going to the bathroom. Before leaving for the day. } After blowing nose, sneezing, or coughing into tissue. When hands are visibly soiled. Assist/observe young children to ensure proper hand washing.

# Illness while on the School Site

---

- Children and staff with COVID-19 symptoms should be separated away from others until they can be sent home. Students who are sick and not already wearing a mask should be provided one to wear unless the student has a contraindication to doing so. If a mask is not tolerated by the ill student or staff member, other staff should be masked and follow maximum physical distancing guidelines (at least 3 feet away).
- Ask ill student (or parent/guardian) and staff whether they have had potential exposure to COVID-19 in the past 14 days meeting the definition of a close contact. Individuals should be sent home and referred to a healthcare provider. Persons with COVID-19-compatible symptoms should undergo COVID-19 testing.
- Schools with testing capacity should test ill students and staff, consistent with any federal and state requirements, including requirements regarding parental consent. Ill individuals who test positive should be reported to the LHD and contact tracing should begin. Ill individuals that test negative should be referred to a healthcare provider, who may consider additional COVID-19 testing.



# Attendance Presentation from the Month of November 2021



Gerald Fitzhugh, II, Ed.D.  
Superintendent of Schools  
“The Teaching Superintendent”  
December 14, 2021  
Focus Core Area Number 1-4  
District Goal Number 1-4



**Chronically  
Absence  
Categories  
are  
Identified As:**

<b>Absences Category</b>	<b>November Days Absent</b>
High Chronic Absences	6 days or more
Significant Chronic Absences	4 to 5.99 days
Modest Chronic Absences	2 to 3.99 days
Low Chronic Absences	0 to 1.99 days



# November Absences by Category

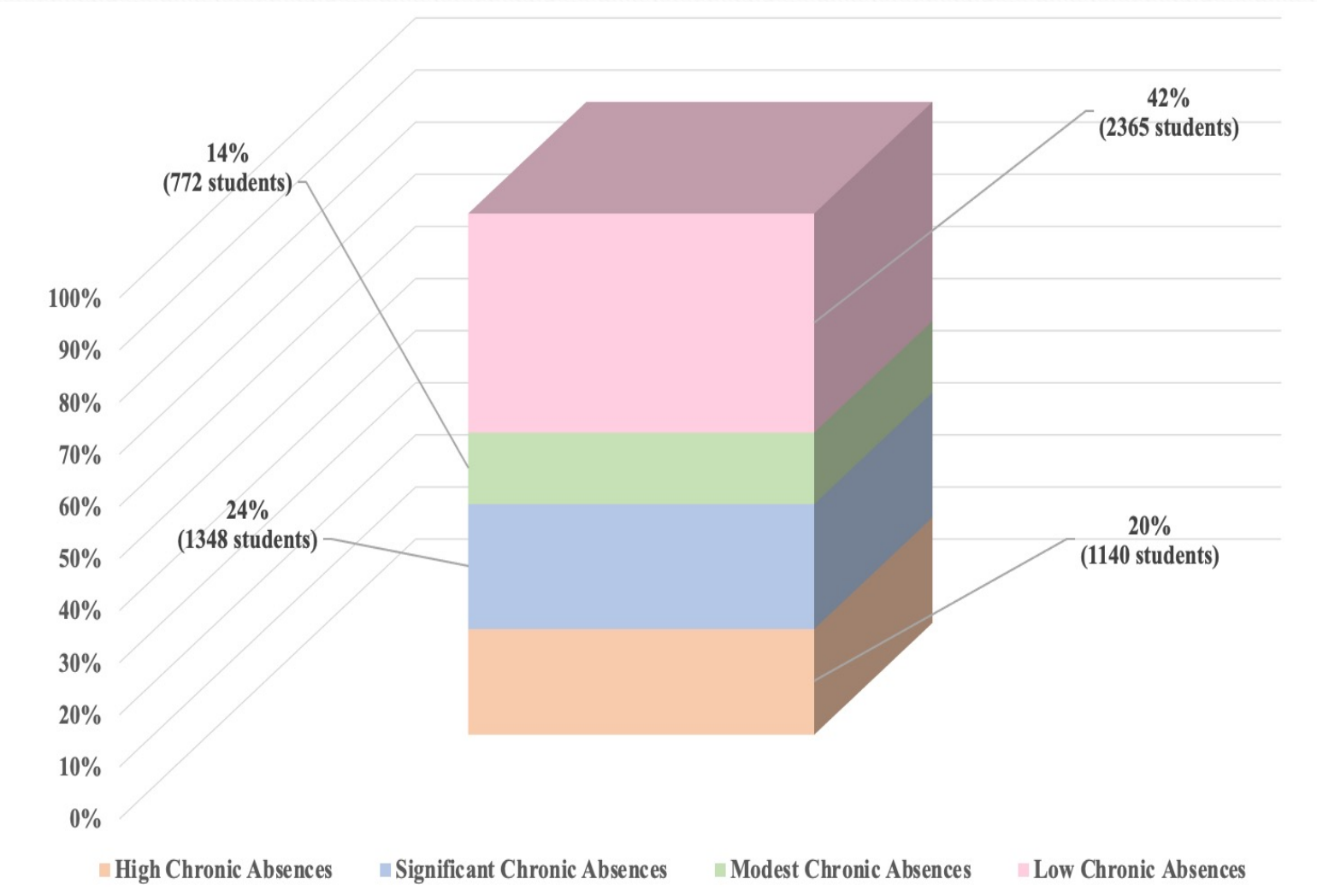

### November Absences by School Early Childhood Program

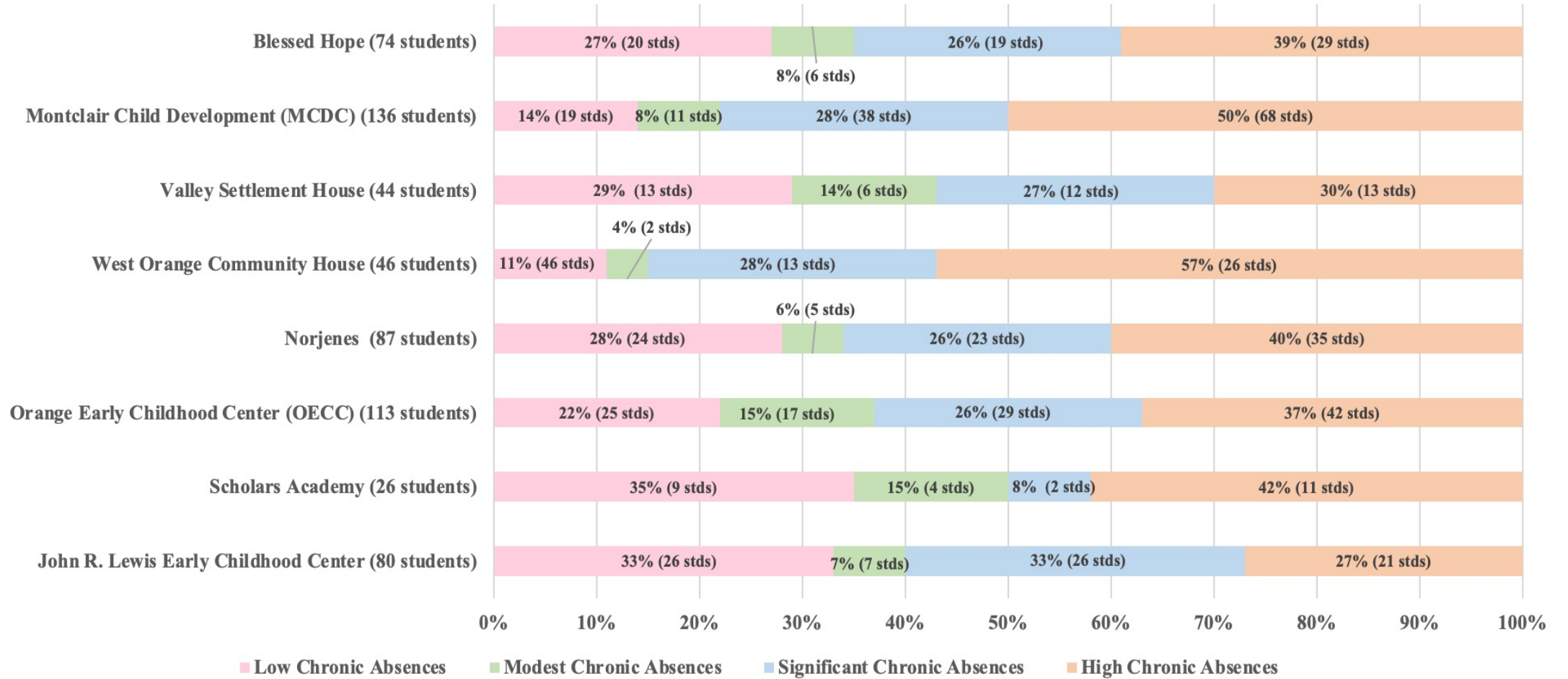



### November Absences by School Kindergarten through Grade 7

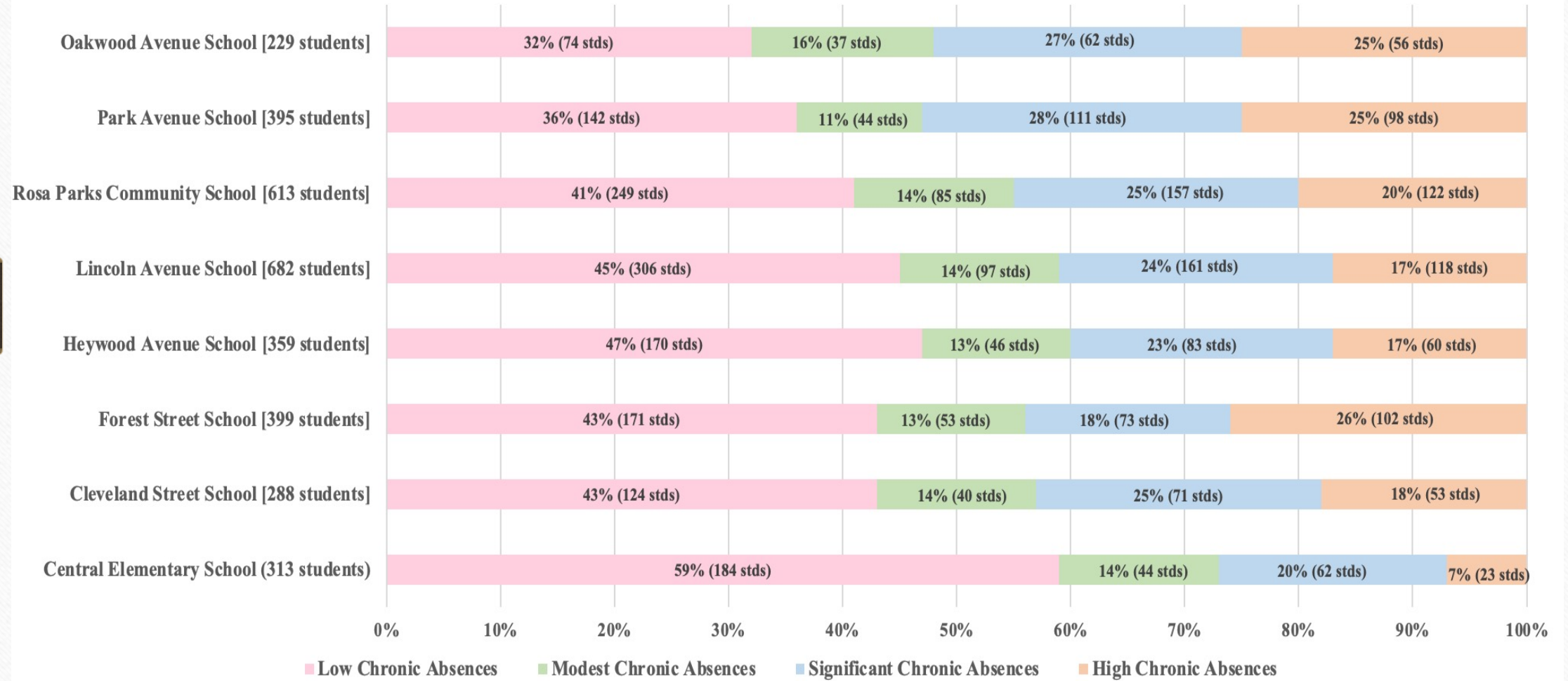

### November Absences by School Grades 8 through 12

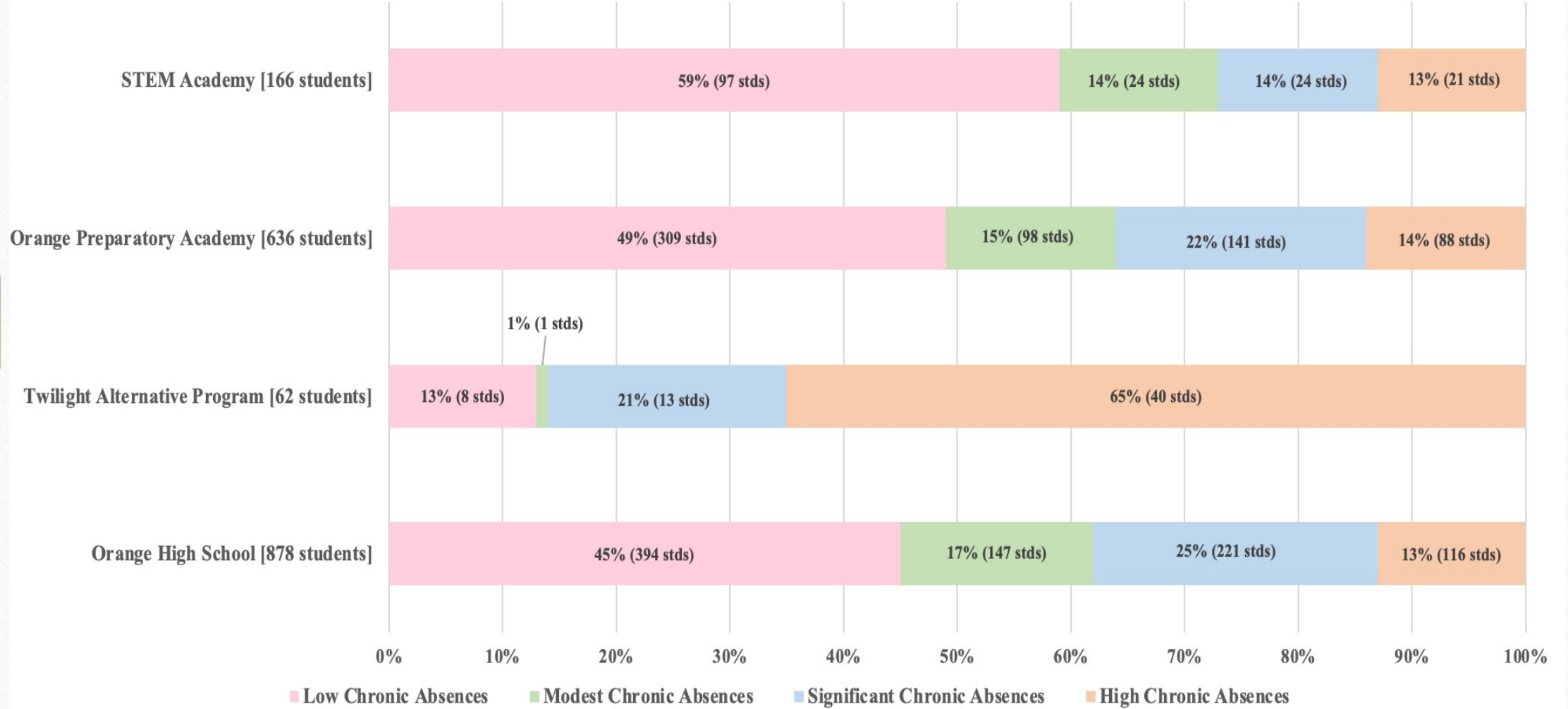



## November Absences by Grade Level

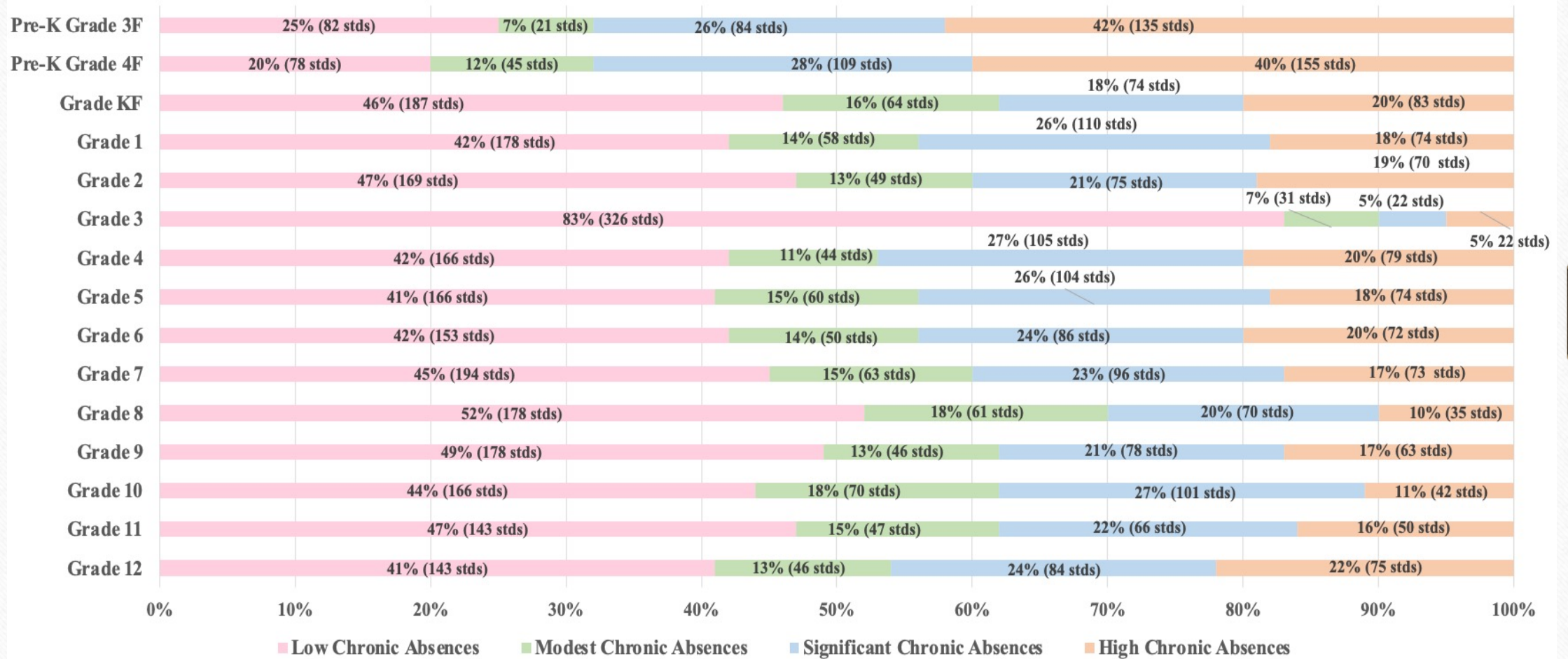

November 2021  
Average Daily Attendance Percentages  
**\*State Average is 95%**  
District Average Daily Attendance was 95%

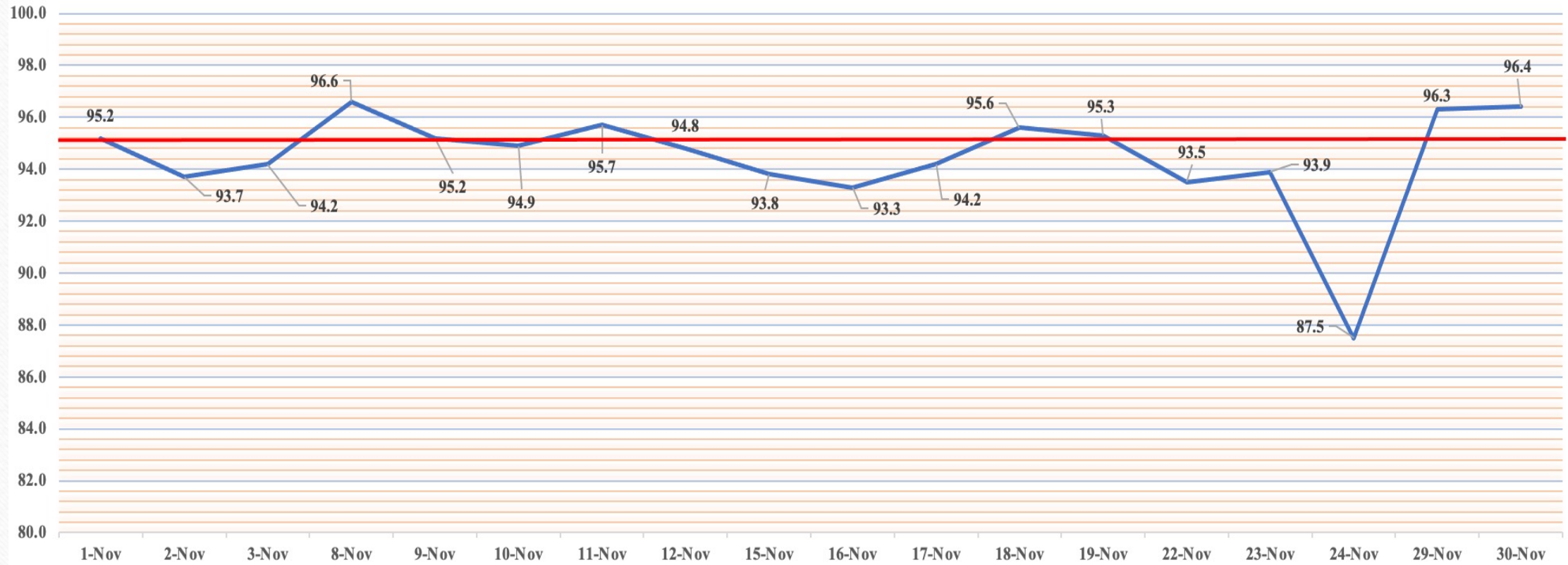



# The Orange Public Schools Facilities Update



Jason Ballard  
School Business Administrator  
December 14, 2021  
Focus Core Area Number 1-4  
District Goal Number 3





## District Facility Maintenance & Custodial Services Update

---

THOROUGH DAILY CLEANING AND  
DISINFECTING OF ALL TOUCH  
POINTS IN THE BUILDING;  
(EXAMPLES INCLUDE BUT NOT  
LIMITED TO DOOR HANDLES,  
BATHROOMS, ENTRANCES, EXITS,  
AND BANISTERS)

---

POWER CLEAN INC. (PCI) HAS BEEN  
AN IMPORTANT PART OF DISTRICT  
MEETINGS BASED ON UPDATES  
RELATED TO COVID-19 MANDATES  
AND EXPECTATIONS.



# November 2021 District Updates

---



In the month of November, we continued to address facilities concerns as they are inputted into the School Dude module. We have addressed issues from replacing ceiling tiles to plumbing concerns.

# Oakwood Avenue School

---

- It was reported that we did not have hot water at Oakwood Ave School. The investigation revealed that the hot water tank was not properly working, and the circulating pumps also stopped working.



Oakwood  
Avenue School





# Lincoln Avenue School

---



- On November 18, 2021, a pipe was leaking in the media center at Lincoln Avenue School. We had to repair a two and a half copper pipe, furnish, install new flange, bolts and gaskets.



# Work Orders

---



- As stated earlier, we are addressing work orders as we received them from the school and district levels. Everyday the team is out in the field addressing issues as they are reported.



# Work Orders

---



- On November 30, 2021, it was reported that a large tree branch obstructed parking spaces in the Orange High School parking lot . The team immediately addressed the issue by cutting the tree and ultimately removed the debris.





# John Robert Lewis Early Childhood Center

On November 5<sup>th</sup> the signage for JRLECC was installed. Doesn't it look great?



# The Month of December 2021

---



- Mr. Vasquez and I will continue to meet with the Schools Development Authority and Terminal Construction every two weeks to keep the district up to date with the ongoing progress at the Orange HS renovation project. Bi-weekly meetings will continue regarding the renovation progress at Cleveland Street School.



# Reminder from the Office of Facilities



We will continue to update the community, staff and Board of Education Members of all progress.



The health and safety of staff and students are at the apex of all facilities undertakings.



# District Updates

The School Development Authority in conjunction with the School District, will take part in the Ribbon Cutting of the New Wing at Orange High School at 11:00 AM on Friday, December 17th. This is a great moment for the school district as well as for our students and alumni of Orange High School. A sincere thank you to all who have contributed to the success of this project. This is truly an exciting moment for Orange High School.



# Stock Market Game Competition

- The competition ended Friday, December 10th, here are stats for the Northern NJ Region
- We placed 2nd & 7th for Middle School Region.
- We placed 5th & 7th for High School Region.
- The state had a total of 1,833 Teams. Do you see this great news?



# Stock Market Game Competition

- Six Orange Prep students placed in the top 100 for middle school students out of 332 participants.
- Twenty-three Orange Prep students placed in top 100 for high schools out of 659 participants.
- Second place middle school winner will receive special recognition from the SIFMA Foundation.
- Thank you Mr. Gamble from Orange Preparatory for leading this effort and sharing the great news!



# Puffs Play

- **Reminder: Remaining Puffs Performance at Orange Preparatory Academy**
- December 17th-7:00 PM
- December 18th-2:00 PM
- "Puffs" is a humorous and heartwarming play set in a very familiar wizarding world and will appeal to students of all ages and their families. Tickets that were purchased prior to the date change will still be honored. The talent on the stage left me completely speechless. The students were well prepared... Thank you as well to our great production team. Your support of the craft and the students is truly appreciated. Way to go!



# Finance Presentation

---

Mr. Lamont T. Zachary  
Assistant School Business Administrator  
December 14, 2021  
District Goal Number Three  
Strategic Plan Core Focus Areas 1-4



# Reminder School Closure Days

- December 23, 2021 at 12:30 PM all district schools and offices will close for the holiday break
- The district and school will remain closed through Sunday, January 2, 2022. Schools will reopen at regular time on Monday, January 3, 2022.



Reminder: The Orange App  
Have you signed up?  
You know I am sending blasts out for folks to sign up...Stay Tuned

---



Announcing the NEW  
**Orange Public Schools**  
Mobile App!



Designed specifically to keep you better informed, in REAL time!

Available for Apple and Android devices.

The app is **FREE** and available for **download today. You are encouraged to sign up.**

Download the new app in 3 easy steps:

1. On your smartphone, go to the iTunes App Store® or Google Play®
2. Search **Orange Public Schools**
3. Then select our **Orange Public Schools** app for free download

School news in the palm of your hand, your new Orange Public Schools mobile app is just a few taps away.

Available on the  App Store  Google play

**Download it today!**



# Orange Public Schools Social Media





## Social Media Hashtags:

#GoodtoGreat

#MovingintoGreatness

#OrangeStrong

## Follow us:

-  - Orange Public School District
-  - @ops\_district
-  - opsdistrict
-  - Orange Public School District

